Proposed Harvester Model for Palm Date Fruit

Nourani, A.^{1*} and Pegna F. G.²

¹Scientific and Technical Research Centre for Arid Areas (CRSTRA), Biskra, Algeria,
²Department GESAAF, University of Firenze, section biosystemsengineering, Firenze, Italy.

Nourani, A. and Pegna F. G. (2014). Proposed harvester model for palm date fruit. International Journal of Agricultural Technology 10(4):817-822.

Abstract Facing the increasing of the date palm trees plantings in Algerian, it is increasingly planted, difficult to ensure the harvest in better moment due the lack of skilled workers and the high cost of this operation. These reasons have encouraged us to propose an alternative to this farming operation such is still carried out manually imposing hurting and dangerous efforts. Therefore, we have developed model of cluster dates harvesting machine. The proposed machine was designed in SolidWorks computer software. This harvesting machine includes four components, namely: stabilizing platform, lifting device, lowering device and cutting device, can be carried around manually and fixed at the base of any palm trunk and used to cut and lower whole clusters without having to climb the palm.

Keywords: mechanization, date palm, dates harvesting machine, SolidWorks, climbing of palm tree.

Introduction

Date palm requires particular care especially at the level of the crown, such as de-thorning, pollination, spraying, thinning, pruning, clusters arrangement and positioning of anti-breakage-supports, covering and, finally, harvesting. All these operations are still carried out manually, which requires a lot of time and cost, as well the danger of palm climbing. Harvesting of dates fruit is considered as the most important of date palm farming operation.

Within this context, several researchers are endeavoring to develop systems to make access to the top of palm trees easier to the worker in order to suit all crown-related operations of date palms, such as Abdelouahhab *et al.* (2002) developed a Walk-Up elevator, Al-Suhaibani *et al.* (1990; 1992; 1998) designed and manufactured a date service machine, Basic concept for a tree-climbing buggy are reviewed by Bankhar and Akyrut (1995), a tractor-mounted date palm tree service machine was developed and tested by Moustafa (2005), Keramat *et al.* (2007; 2008a,b) proposed lifting model for gripper date palm

*Corresponding author: Nourani A.; E-mail: nourani83@gmail.com

service machine, A self-moved ladder, consisting of 15 m extendable sliding ladder mounted on a mini tracked dumper has been developed (Garbati, 2008).

In fact, no detailed literatures were found on harvest dates palm machine up to now, except a climbing machine was developed and tested to harvest and service date palm trees (Shamsi, 1998).

In these papers, an innovative harvester is proposed which is able to carry out manually and fixed at the bottom of any palm trunk and used to cut and lower whole clusters without having to climb the palm.

Materials and methods

Current methods of harvesting dates in Algeria

Currently, dates harvesting requires manual effort from the farmer by climbing up the palm tree to cut the stalks and lowers the whole infructescences with a rope cut manipulated by a worker on the ground. However, this method is very difficult and dangerous for the climber. Besides, the decreasing availability of skilled labor (climbers) in face of the increasing number of trees and the high cost of the harvesting operation is considered a most constraint for the farmers.

General requirements of a dates cluster harvesting machine

Based on a survey was carried out in the Biskra province due to its importance in Algerian date production, the main characteristics of the suitable harvesting machine were defined: manually operated by one single operator easy to transport easy to construct and repair in an averagely equipped blacksmith workshop minimized use of non-manual power capable of working in any kind of plantation layout and soil conditions capable of reaching clusters up to 8 m high capable of cutting the cluster's stalk and collecting and lowering the cluster to the ground economically acceptable in date palm cultivation economy.

Results and discussions

The proposed machine was designed in SolidWorks computer software (Fig.01). A first prototype was successively refined and turned into a 1:3 scale (Fig.02) in the workshop of the GESAAF Department, University of Firenze (Italy).

Description

As shown in the figure (Fig.03), the harvesting model compounds four principal elements, namely:

Stabilizing platform: It is built to support the other components. It is attached vertically directly on the trunk of the palm. It secures the fixation and stability of the machine during the work by feet and a lashing belt.

Lifting device: It is a telescopic mast extendable with the use of reel and cables actioned by two manual winches and supported by the platform with two mobile joints to make it mobile and fixable. This device is used to raise and lower the cutting device and the basket.

Basket: The basket is needed for containing the cluster and allowing it to be lowered without damage. It will make by a ring holding a textile bag. It is mounted through the basket support at the upper end of the telescopic mast.

Cutting device: This is a rechargeable electric chain saw mounted on an articulated arm, equipped with a return spring and a draw wire. This device is mounted at the upper end of the basket support.

Operation

Setting: The platform is leaned vertically to the base of the trunk so that the feet are well in contact with it and the lashing belt is tightened. The lower end of the platform must be well above the ground in order to allow the telescopic mast to rotate freely.

Extension: the telescopic mast is extended by means of the winches and at the same time the rigging screw (adjuster) is loosened so that the cluster enters into the basket and electric saw is in the appropriate position. The mast is then fixed by aligning the hole of the lower articulation with a suitable hole of the platform and inserting a pin in the holes.

Harvesting and collection: When the cluster is in the basket and the saw is correctly positioned the saw is turned on by the operator with the use of a remote control switch and moved towards the stalk with its draw wire; the cluster then falls into the basket and the basket is let down along the reel by the operator.

This step is repeated for all the clusters of the same part of a plant then the equipment must be placed on the other side. When finished the mast must be lowered for transporting to another plant.

Performance and evaluation of the machine

The harvesting model that has been developed has proved to allow one single operator to harvest all the clusters of a palm tree by placing the equipment on two different sides of the trunk. According to SolidWorks software estimation, this equipment weights about 28 kg, so she can hence be transported around the farm manually; the assessment of construction cost is 1,300 euro which makes it affordable for the farmers. This machine developed to be able to harvest clusters to 8 m of height.

According to simulation with SolidWorks software, it was estimated that the harvest of dates cluster takes 3 minutes after installing the machine on the trunk.

Theoretically, one operator is sufficient to run the machine, but makes it easier for the existence of an assistant is needed.



Fig. 1.The designer of a dates cluster harvesting machine



Fig. 2. 1:3 scale of harvester

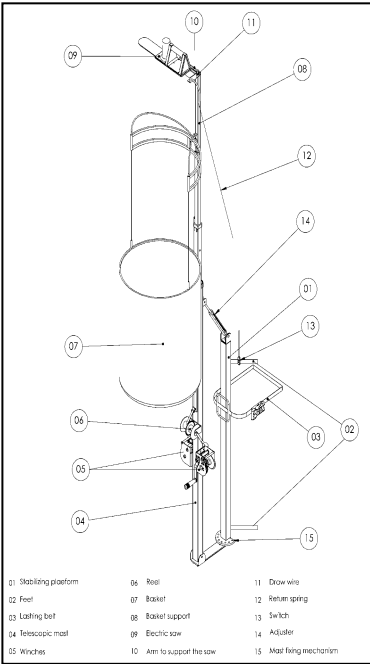

Fig. 3. Diagram of the harvester

Conclusion

The machine that has been developed to harvest whole date clusters from the ground, without need for the operator to climb up the tree, hence avoiding fatigue and risks consequent to this operation, and can represent an interesting device for farmers to face lack of skilled labor. The time needed for harvesting and its cost make it an affordable alternative to manual harvesting and can represent the link pin between manual and mechanical motorized harvesting.

References

- Abdelouahhab, Z. and Arias Jimenez, E. J. (2002). Date palm cultivation. FAO Plant Production and Protection Paper no. 156.
- Al-Suhaibani, S. A., Babaeir, A. S., Kilgour, J. and Flynn, J. C. (1988). The design of a date palm service machine. *Journal of Agricultural Engineering Research* 40:143-157.
- Al-Suhaibani, S. A., Babaeir, A. S. and Kilgour, J. (1990). Design specification of a date palm service machine. *Agriculture mechanization in Asia, Africa and Latin America* 21:53-60.
- Al-Suhaibani, S. A., Babaeir, A. S., Kilgour, J. and Blackmore, S. (1992). field tests of the ksu date palm machine. *Journal of Agricultural Engineering Research* 51:179-190.
- Bankhar, A. A. and Akyurt, M. (1995). A tree-climbing buggy for date palms. *The Fourth Saudi Engeneering Conference IV*. pp. 171-177.
- Garbati, P. F. (2008). Self-moved ladder for date palm cultivation. *International Conference: Innovation Technology to Empower Safety, Health and Welfare in Agriculture and Agro-food Systems, Ragusa – Italy*.
- Keramat, J. M., Jafari, A., Mohtasebi, S. S. and Rafiee, S. (2008a). Engineering properties of date palm trunk applicable in designing a climber machine. *Agricultural Engineering International: the CIGR Ejournal*, Manuscript FP 08 002.
- Keramat, J. M., Mirasheh, R. and Jafari, A. (2008b). Proposed lifting model for gripper date palm service machines. *Agricultural Engineering International: the CIGR Ejournal*. PM 08 018.
- Keramat, J. M., Jafari, A., Rafiee, S. and Mohtasebi, S. S. (2007). A survey on some physical properties of the date palm tree. *Journal of Agricultural Technology* 3:317-322.
- Moustafa, A. F. (2005). Development of a tractor-mounted date palm tree service machine. *Emirates Journal of Agricultural Sciences* 17:30-40.
- Shamsi, M. (1998). Design and development of a date harvesting machine. (Ph.D. thesis). Silsoe College, Cranfield University.UK.

(Received 12 May 2014; accepted 30 June 2014)